



PRIME 700

BRIDGE STONE SAW

Designed and made in Italy



WATER TANK

Realized in ABS material, crash and consumption proof.

- Plate to guide the cutting rubble from the recycling water's area to the tank

STORAGE

Build to reduce at the maximum the encumbrance during the carriage and above all the storage space

KIT WHEELS

The wheels are Ø220 mm and can be fixed at the legs by means eyebolts. Due to their conception and for the legs' inclination, are very functional and allow the machine to be easily moved if lightly lifted up by the handles.

	Art. 90650	Art. 90651	Art. 90700	Art. 90701
DIAMOND DISK (not included)	Ø650 mm. (int Ø25,4 mm.)	Ø650 mm. (int Ø25,4 mm.)	Ø700 mm. (int Ø25,4 mm.)	Ø700 mm. (int Ø25,4 mm.)
ENGINE	400V 50/60Hz 5,5Hp/4kW	400V 50/60Hz 5,5Hp/4kW	400V 50/60Hz 5,5Hp/4kW	400V 50/60Hz 5,5Hp/4kW
ROTATION SPEED	1400 rpm.	1400 rpm.	1400 rpm.	1400 rpm.
AMPEROMETRICAL PROTECTION	10-16A	10-16A	10-16A	10-16A
MAX CUTTING LENGTH	640 mm.	640 mm.	615 mm.	615 mm.
MAX CUTTING DEPTH AT 90°	250 mm.	250 mm.	275 mm.	275 mm.
MAX CUTTING DEPTH AT 45°	163 mm.	163 mm.	180 mm.	180 mm.
WATER RECYCLING PUMP TYPE	S3 standard	S3 standard	S3 standard	S3 standard
KIT WHEELS	Standard	Standard	Standard	Standard
LASER INSTRUMENT	Optional	Standard	Optional	Standard
DIMENSION MACHINE IN SERVICE	720x1950x h. 1750 mm.	720x1950x h. 1750 mm.	720x1950x h. 1775 mm.	720x1950x h. 1775 mm.
DIMENSION MACHINE IN STOCK	720x1950x h. 975 mm.	720x1950x h. 975 mm.	720x1950x h. 1000 mm.	720x1950x h. 1000 mm.
DIMENSION 2 MACHINES ON PALLET	720x2250x h. 1760 mm.	720x2250x h. 1760 mm.	720x2250x h. 1760 mm.	720x2250x h. 1760 mm.
NET WEIGHT	115 Kg	115 Kg	117 Kg	117 Kg

BATTIPAV™

MACCHINE PER EDILIZIA | MACHINES FOR BUILDING

Z. i. 2 - Via Cavatorta, 6/1 | 48010 Cotignola (Ra) | ITALY
Tel. +39 0545 40004 | Fax +39 0545 41724
www.battipav.com | sales@battipav.com

AUTHORIZED DEALER:



January 2011

APPLICATION

Built to cut brick blocks, natural stones, concrete blocks and poroton

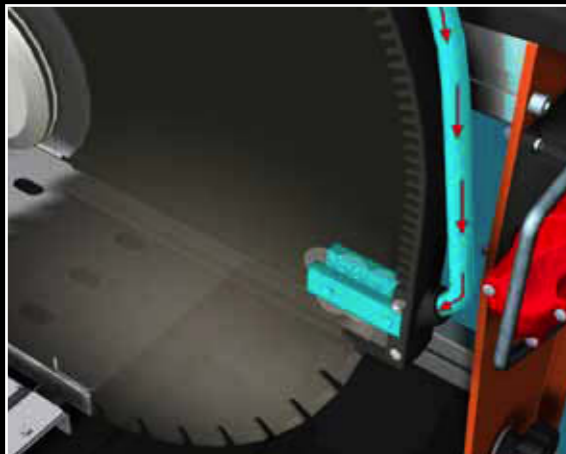

Spray system **SPRAY SYSTEM**

Patented system that improves the lubrication of diamond disk and ensures higher cutting performance and longer-lasting blades.



45° CUT
Position 45° angle cuts.

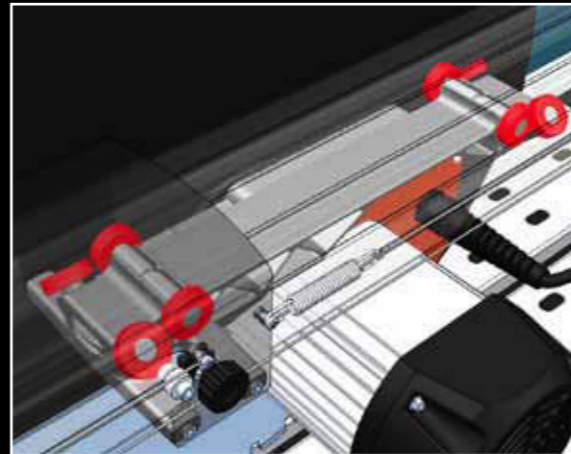

CARRIAGE ENGINE GROUP
The carriage engine group slides with 8 ball-bearings on interchangeable stainless steel track. So doing the sliding is very fast and precise.



CUT
Cutting position for straight cuts. It works with disk Ø 650 or 700.



CONTROL BOARD
Control board includes:

- Switch with release coil.
- Overheat protection with manual reset in the event of the disk jamming
- Laser instrument for the maximum cutting precision (optional in standard version).



CUTTING PROGRESS SYSTEM
The **CUTTING PROGRESS SYSTEM** with **HANDWHEEL** adjust the movement of the cutting head forward or behind



LASER TRACER

- Connected directly to the net.
- Bulb with millimetrical adjustment of the ray in three space's directions.
- Lens with interchangeable protection glass.

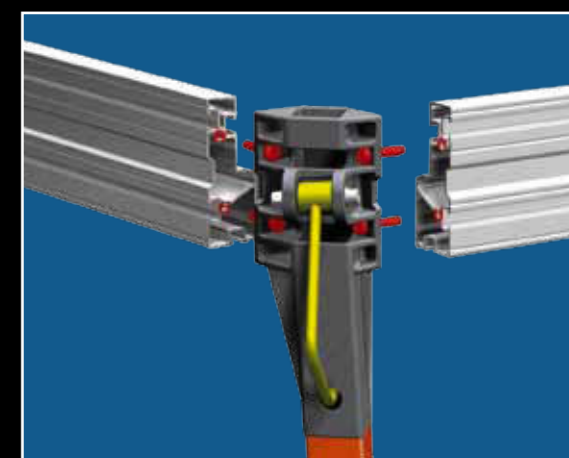

Fast LEG FAST LEG
Slide inside special attachments, integrated to the structure and bell-shaped inclined, assuring great stability at the machine.

- Quick and strong locking with eccentric.
- Adjustable height in every position, with three prefixed positions.



Our submerged pump is marked with the registered trademark **AxT**, the acronym of "Acqua per Tagli" which stands for **Water for Cutting**; its certifies its provenance and authenticity.