

Strong framework bridge holding the head group



#### KIT WHEELS

The wheels are Ø220 mm and can be fixed at the legs by means eyebolts. Due to their conception and for the legs' inclination, are very functional and allow the machine to be easily moved if lightly lifted up by the handles.



#### STORAGE

Build to reduce at the maximum the encumbrance during the carriage and above all the storage space.

# EXPERT 700

## STONE SAWS

*Designed and made in Italy*



Art. 9700	
DIAMOND DISK (not included)	Ø700 mm. (int Ø25,4 mm.)
ENGINE	400V   50/60Hz 5,5Hp/4kW
ROTATION SPEED	1400 rpm.
AMPEROMETRICAL PROTECTION	10 A
MAX CUTTING LENGTH	550 mm.
MAX CUTTING DEPTH AT 90°	270 mm.
MAX CUTTING DEPTH WITH 2 RUNS	340 mm.
WORKING TABLE SIZE	516 x 520 mm.
WATER RECYCLING PUMP TYPE	S3 Type 230V 50Hz
KIT WHEELS	Standard
DIMENSION MACHINE IN SERVICE	1480x760x h. 1620 mm.
DIMENSION MACHINE IN STOCK	720x1600x h. 1080 mm.
DIMENSION 2 MACHINES ON PALLET	720x1600x h. 1800 mm.
NET WEIGHT	95 Kg.

**BATTIPAV**<sup>TM</sup>  
MACCHINE PER EDILIZIA | MACHINES FOR BUILDING

Z. i. 2 - Via Cavatorta, 6/1 | 48010 Cotignola (Ra) | ITALY  
Tel. +39 0545 40004 | Fax +39 0545 41724  
[www.battipav.com](http://www.battipav.com) | [sales@battipav.com](mailto:sales@battipav.com)

AUTHORIZED DEALER:



#### APPLICATION

Built to cut bricks, poroton blocks, marble blocks and all the different kind of materials for the building sector.

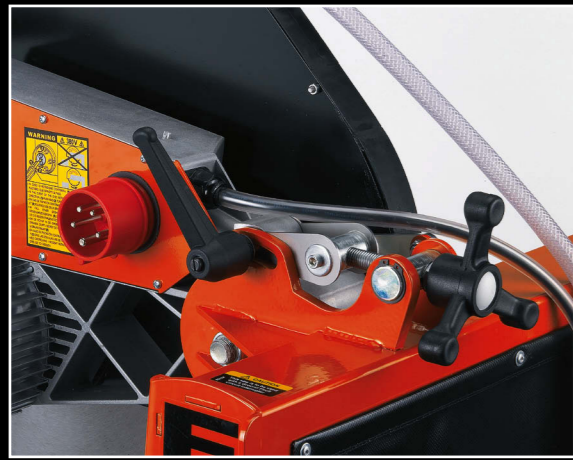

Adjustment system of the cutting height with an hand wheel and relevant locking lever.  
Possibility to make cuts with **2 RUNS** (max depth 340 mm).



Cutting position with sliding carriage.  
It works with disk from Ø650 to Ø700 mm.

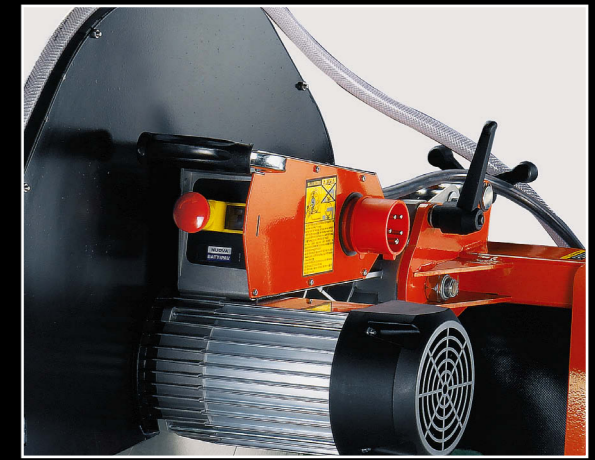

**CONTROL BOARD**

- Switch with release coil
- Overheat protection in the event of the disk jamming
- Mushroom-head push button to stop the machine

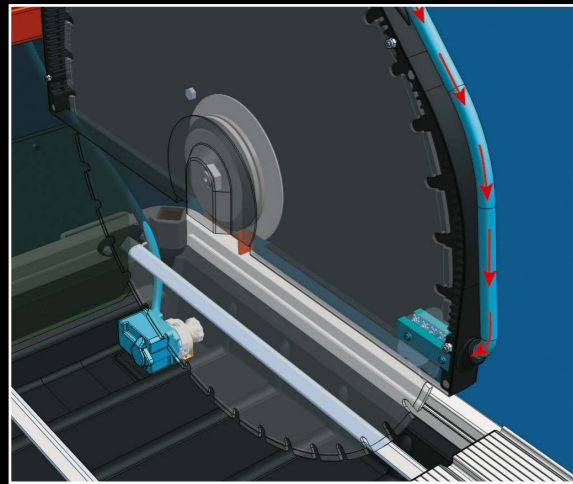

**Spray system**

DISK'S LUBRICATION

**Fast LEG**

LEG FASTENING SYSTEM



ORIGINAL RECYCLING PUMP

**wdec**  
WATER DECANTING SYSTEM